

Thinline Arch Square

Suspended Mounting

Installation Manual

Safety & Warnings:

Failure to follow these instructions and warnings may result in death, serious injury or significant property damage.



Warning: Risk of Fire and Electrical Shock. Fixture must be installed by a qualified electrician only in accordance with National, Local Building, and Electrical Codes. Disconnect power at the electrical panel before servicing.

General contractor is responsible for the installation of appropriate anchors to support the load of the fixture at positions detailed in the installation manual. Installation of such anchors or other support systems must be completed in accordance with applicable building/installation code.

Mounting Locations

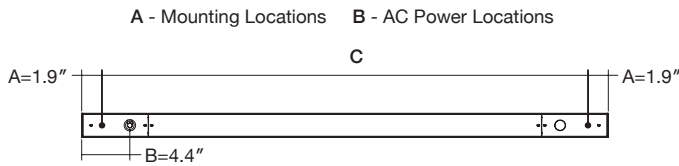

Models	DTL Arch Square 4	DTL Arch Square 6
Mounting Lengths (C)	44.5"	68.5"

Note: For continuous run refer to approval drawing.

Steps

- Ensure the power to be connected to the fixture is turned off.
 - Install junction box inside ceiling. Provide sufficient power wiring length to junction box.

2(a). For Drywall Mounting

- Install 1/4-20 toggle anchor into drywall surface. Ensure approximately 3/4" of thread protrudes from the drywall surface.

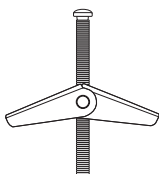

1/4-20 Toggle

For Drywall Mounting - Continued

- Insert the aircraft cable open end into the large opening in the coupler and pass the aircraft cable through until fused end stops in the coupler.

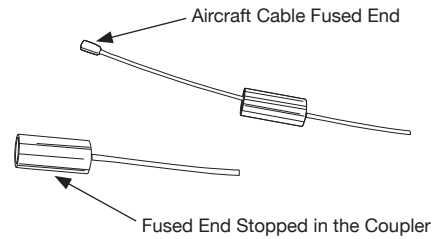

2(b). For T-Grid Mounting

- Install appropriate caddy clip onto tbar structure with provided 1/4-20 bolt.

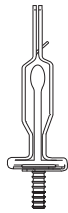

3(a). For Aircraft cable. Install aircraft cable support as per below schematic

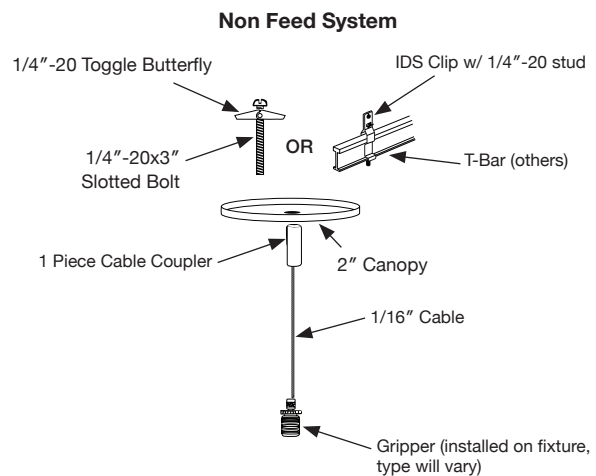
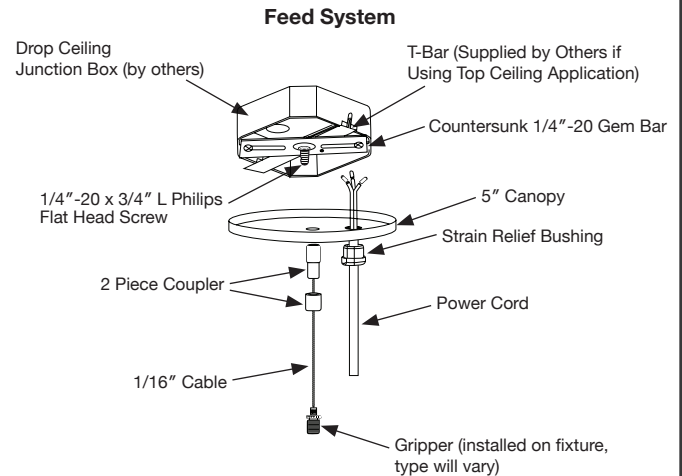

3(b). For Threaded Rod Mounting

- For 1/4-20 UNC threaded rod mounting - screw 1/4-20 UNC hex nut onto the threaded rod, install threaded rod into the nut mounted on the fixture, and lower the hex nut toward the fixture to secure the rod in place.
- The mounting of opposite end of the threaded rod to supporting structure is the responsibility of the installer.

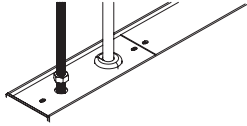

- 4
- Slide the open end of the aircraft cable through the cable gripper as shown below.
 - To release the aircraft cable, first support the weight of the fixture, then press the collar of the gripper inward and pull the cable out. Ensure the fixture is level.

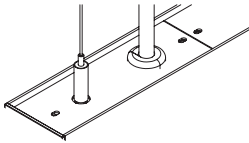

Continuous Run

Steps

1. Before starting assembly make sure that there is no power connected to the fixture.
2. Note that all fixtures are labeled in the order of assembly.
3. It is advisable to assemble the complete fixture (FIG.1) on the ground and then raise it using the aircraft cable provided.

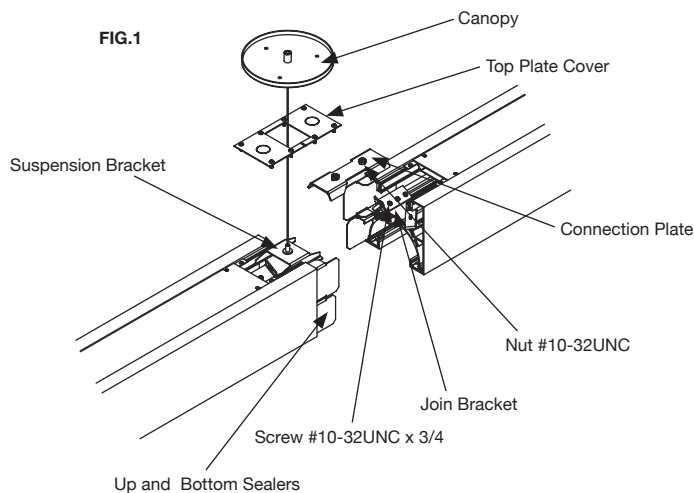

4. The fixture is shipped as fully preassembled sections. To connect the section unscrew and remove the top cover plate (FIG.1).
5. Remove the Hex Nut #10-32 UNC and remove the connection plate (FIG.1). Reserve for later.
6. Remove the screws that are attached to the join brackets FIG.1.
7. Make all electrical connections according to electrical code.
8. Slide the Up and Bottom sealers into the extruded vertical channels and insert removable suspension.
9. Tie the two join brackets by using the screws #10-32UNC that have been removed on Step 5.
10. Attach and assemble the connection plate from Step 5 using the 2 x Hex Nut #10-32 UNC
11. Move the suspension bracket in the middle position between the two connected sections and put back the top cover plate.
12. Repeat same sequence Steps 4 to 11 for the other sections (FIG.2)

FIG.2

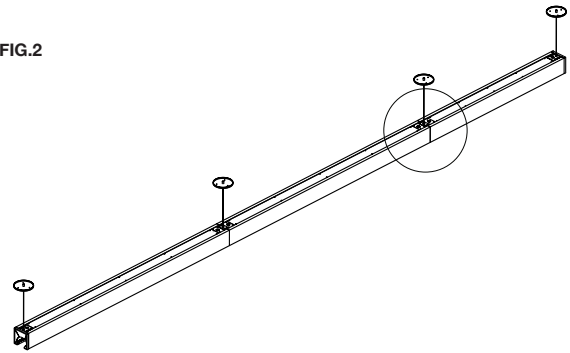

13. Fixture is complete, power the unit to see that everything is working properly, then disconnect.
14. Pull up and insert aircraft cable in the grippers and level the fixtures.
15. Power the unit.

This document is the exclusive property of delviro energy inc. It is supplied in confidence and must not be used for any purpose other than for which it is supplied. No disclosure, reproduction or use of any part of the enclosed may be made except by permission from delviro energy inc.

Specifications subject to change without notice.
© delviro energy