

Thinline 2.25

Continuous Run

Installation Manual

Safety & Warnings:

Failure to follow these instructions and warnings may result in death, serious injury or significant property damage.



Warning: Risk of Fire and Electrical Shock. Fixture must be installed by a qualified electrician only in accordance with National, Local Building, and Electrical Codes. Disconnect power at the electrical panel before servicing.

General contractor is responsible for the installation of appropriate anchors to support the load of the fixture at positions detailed in the installation manual. Installation of such anchors or other support systems must be completed in accordance with applicable building/installation code.

Steps

1.
 - Remove the screws and top covers on both sides of the fixture joint in order to expose the inner fastening brackets (Fig. 1).
 - Slide the suspension bracket to one side of the joint.

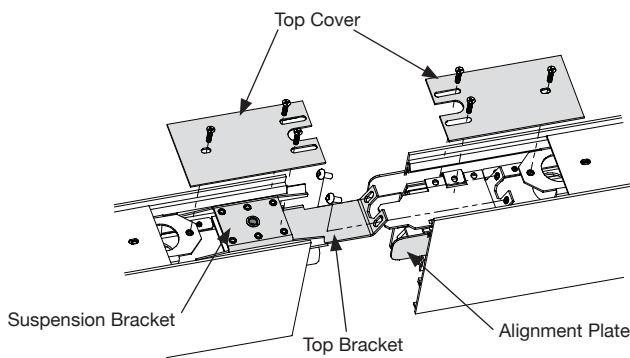

Fig. 1 - Continuous Run - Top Bracket

2.
 - Remove the lenses from the bottom of the fixture by sliding them out.
3.
 - Connect the power and dimming wire harnesses (power to power, dimming to dimming) between segments according to applicable national electrical code and wiring diagram. Move the wire harnesses into the empty space of one of the fixtures.
4.
 - Using the two mounted alignment plates (see Fig. 1), manually join the two fixtures.
5.
 - From the top of the fixture, connect and fasten the top brackets using two supplied #6-32 screws (Fig. 1).
 - Slide the suspension bracket to the middle of the joint.

6.
 - From the bottom of the fixture, slide the joining bracket onto the two flanges on the bottom brackets and tighten using two #6-32 screws (Fig. 2) until segments are in firm contact.
 - Repeat this process on the opposite side of the fixture joint.

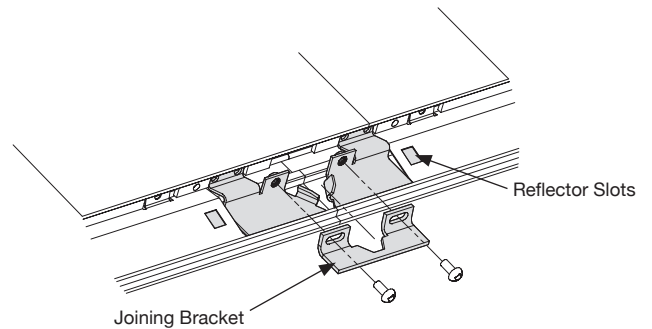

Fig. 2 - Continuous Run - Bottom Bracket

7.
 - Assemble the joint reflector over the brackets and into the adjacent slots (Fig. 3). Repeat for both sides of the fixture joint. Once complete, replace lenses.

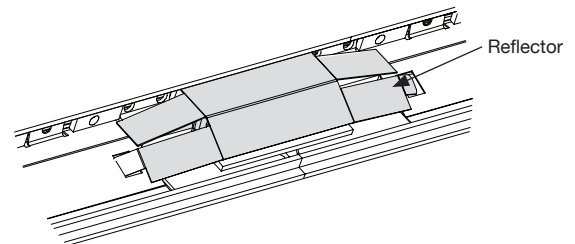

Fig. 3 - Continuous Run - Bottom Reflector

8.
 - Make sure that no wires are pinched or obstructed by the fixture joints. Replace the screws.
9.
 - Inspect the joints for any visible separation of the two fixtures. If any gaps exist, manually fill these gaps with the provided silicone.
10.
 - Repeat for the remaining fixture joints.

This document is the exclusive property of delviro energy inc. It is supplied in confidence and must not be used for any purpose other than for which it is supplied.

No disclosure, reproduction or use of any part of the enclosed may be made except by permission from delviro energy inc.

Specifications subject to change without notice.

© delviro energy